

VELSTONE SEAMING AND JOINING

TOOLS REQUIRED

Clean white rags, Denatured Alcohol (cleaning solvent), Crocodile clamps, Gripper Clamps, Sash Clamps, Sand Paper (150 Grit), Wax Paper, Adhesive Applicator Gun

PREPARATION

Reaffirm the edges prepared by the routing operation are square and the dry joint is correct.

Do not proceed if in any doubt (it is preferable to go back to previous stage rather than make a bad seam). Lightly sand the edges using 150 grit sand paper gripped on a hard wood block. Light sanding improves the adhesive bond. Make only one or two passes to score the edges. Straightness of the edge may be lost by heavy sanding. Ensure that the wooden block is moving square onto the edge and is not rounding off the sharp corners. Rounded or tapered corners or edge will never yield a good quality joint. Clean the work bench and place wax paper on the bench at the location of the joint. This will prevent the dust from the work bench contaminating the joint and will also prevent the Adhesive from bonding the work piece to the table.

Ensure that the working environment is free from dirt and dust. Clean the dust from the sanded edges using a clean rag and follow it up with a rag moistened with Styrene Monomer, Denatured Alcohol or an equivalent colourless, cleaning solvent. Now do not touch the edges by hand until the seam has been made and the adhesive has hardened. Dirt and grime will irrevocably degrade the joint quality.

MIXING THE ADHESIVE

Warning: Read the safety instructions supplied with the adhesive before use! It is advisable to use latex gloves during adhesive mixing and application to protect the hands.

The two part Adhesive is specially formulated by VELSTONE INTERNATIONAL Ltd. The adhesive is tinted to match the VELSTONE sheet colour being used. Confirmation of the right tint should be made by checking compatibility the colour code / group label on the adhesive and the colour of the sheet. The Adhesive is available in a 250 gram Adhesive Cartridge System. The fast setting adhesive takes about 20~40 minutes to harden depending upon ambient temperature. It is not recommended to use the adhesive at ambient temperatures under 20⁰ C.

SEAMING THE BUTT JOINTS

Cut a strip of VELSTONE sheet approximately 100 mm (4") wide by the full length of the butt joint. Bevel the edges, clean the strip and set it aside. This strip is the reinforcement for the butt joint. You can either use Power Grips with Brackets & Turnbuckles system available from Pinske-Edge for clamping or cut two lengths of 75x25 mm MDF and use hot melt adhesive to mount them on VELSTONE sheet (Figure SJ1).

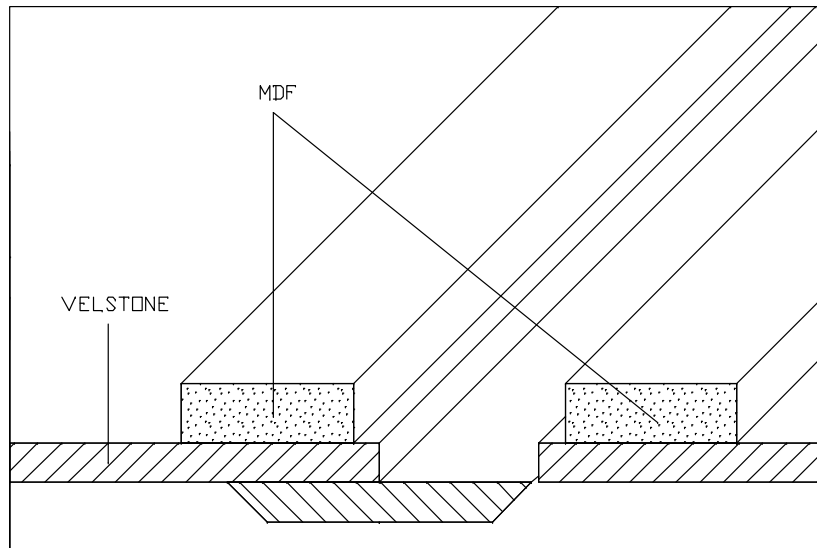

Figure SJ1

These pieces will act as clamping points for pulling the sheet together. Visually check that the edges to be seamed are still clean. Move the edges apart on the table so that both the edges are accessible for Adhesive application. Mount the Adhesive cartridge in the applicator gun and attach the mixing nozzle. Place the reinforcement strip on the wax paper. Apply and spread the adhesive uniformly on the reinforcement strip. Place the first piece of VELSTONE sheet on half the width of the reinforcement strip and clamp both of them together to the work table. Apply adhesive on the edge of

the second VELSTONE piece and push it towards the first piece. Lightly clamp the two MDF pieces together using a standard Gripper clamp. Do not remove or touch the excessive Adhesive squeezed out. If excess Adhesive is not squeezed out all along the length of the seam, it will result in a defective seam. It is advisable at this stage to open the clamps, apply some more Adhesive and clamp again. Do not proceed if this step is not satisfactory.

Check the alignment and the level of the joint using a small, clean piece of thin laminate or hard plastic. Do not use fingers as they may contaminate the wet Adhesive in the seam. If need be add thin packing under one of the sheets to get them both levelled. Now tighten the clamp fully to get the VELSTONE pieces as close as possible. Try to get back to the 'dry joint' level of closeness which is essential for a good seam. Remember! Gap or dry joint will show! Do not wipe the excess Adhesive from the seam surface. It must be untouched until the Adhesive has hardened. The seam will then be ready for the finishing operation approximately in an hour. To remove the excess hardened Adhesive from the seam, first use a router with a flush finish router bit and then finishing off using a random orbital sander with 120 grit sand paper.

SEAMING PERPENDICULAR JOINTS

The Up Stand, or front edge on the counter is a typical example where a perpendicular joint is required (Figure SJ2).

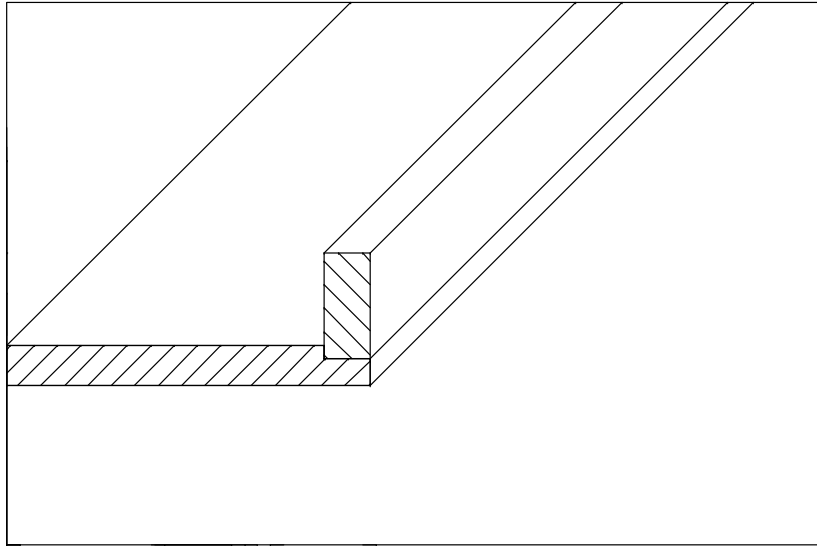

Figure SJ2

The procedure is similar to butt joint except:

- a) It must always be on rebated surface.
- b) Crocodile Clamps must be spaced every 50 mm (2")
- c) The Reinforcement strip is not required.